

**Type** Applicator V100

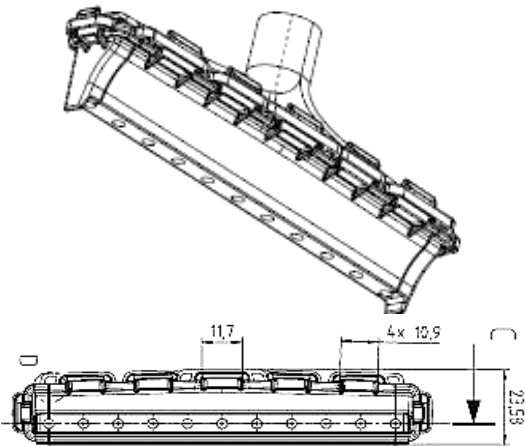

**CAN BE USED FOR**

chemical industry

**ADVANTAGEOUS FEATURES**

They makes easier, simpler and faster application of adhesive. It is recommended to use adhesives where we put

**AVAILABLE**

packaging (also look blister nozzle pack)

**TECHNICAL SPECIFICATION**

<b>Producer ID</b>	PR0950-959
<b>Producer ean code</b> (depend on colour)	_3830065620xxxc
<b>Raw material</b>	PE
<b>Type of carton</b>	pap (5 layer)
<b>Quantity per cardboard box [pcs]</b> (outer box demensions 56,7 x 36,7 x 25,0 cm)	500 pcs/box
<b>Quantity per pallet</b> (pallet dimension 1200 x 800 x 144 mm)	32 boxes (8 row) 16000pcs/pall
<b>pallet height [mm]</b>	approx. 1630
<b>Label packaging</b>	1 label on box 100*120mm (white) On the label will be all data known before the order conformation. All other data will be extra charge.

**Packaging** is standard. Other packaging tipes, will be charged extra.

All extra demans must be known before the order conformation.

\*deviation on weight is always possible (different material, batch, etc)

**Storage** Before use plastic Items in production, keep them at least 24 hours indoor by 18-20°C.

It is strictly forbidden to storage pallet on pallet.

**Foodsafe** If you wish to have food safe certificate for our products, contact us and we will prepare exact for your order.

For colour variation contact [office.slovenia@sopi-closures.com](mailto:office.slovenia@sopi-closures.com)

All products are in tolerance according to DIN 16742 or otherwise agreed

General tolerance: DIN 16901-150